

**State of Iowa  
Energy Center Board  
Meeting Minutes of November 16, 2023  
at IEDA, 1963 Bell Avenue, Suite 200  
Helmick Conference Room  
Des Moines, Iowa  
Or Via Teams Webinar**

**Call to order 1:00 p.m.**

**Board Members Present**

Stuart Anderson, Board Chair  
Craig Just, Vice Chair\*  
Troy DeJooode\*  
Naomi DeWinter\*  
Erik Helland\*\*  
Anne Kimber  
Terry Kouba\*  
Dan Nickey  
Taaf Vermeulen\*  
Matt Washburn\*  
Lanny Zieman

**Absent**

Kelcey Brown  
Debi Durham

**Iowa Economic Development Authority Staff Present**

Brian Selinger  
Amber Buckingham  
Stephanie Weisenbach  
Ryan Young  
Lisa Connell  
Shelly Peterson  
Michelle Cook  
Vicky Clinkscates  
Terry Roberson  
Kanan Kappelman

**Iowa Finance Authority Staff Present**

Dave Powell  
Tim Morlan\*  
Michael Thibodeau\*

**Others Present**

Jon Kallen, Algae Biomass Organization\*  
Stephanie Fromm, Winneshiek County Development and Tourism  
Nathan Seberg, BES Water Solutions  
Mason Blead, Iowa Utilities Board  
Jessica Flannery, Iowa House of Representatives Democratic Research Staff\*  
Jace Mikels, Iowa Senate Democratic Caucus\*  
Lillie Brady, Iowa Governor's Office\*

\*Participated via Teams  
\*\*Joined in person at 1:08 pm

**Welcome & Introductions by Board Chair Stuart Anderson**

Stuart Anderson welcomed everyone to the November 16<sup>th</sup> IEC Board meeting.

**Roll Call**

Michelle Cook did roll call and a quorum was established.

**Consideration of October 3, 2023 IEC Board Meeting Minutes**

Motion by	Dan Nickey
Motion	I move approval of the October 3, 2023 minutes as presented.
Second	Craig Just
Voice Vote	All ayes in favor. Motion approved.

**Fiscal Update – Attachment A**

Terry Roberson reviewed the first report for FY24 expenses through October 31<sup>st</sup>. The report has been tweaked a bit from prior years. Loan receivables balances are not in the report. No loans have been awarded so far this year. Currently there is just over \$10.3M available on the grant program and just over \$12M available on the loan program.

Terry Roberson stated he would be happy to answer any questions, but no questions were asked.

**Competitive Grant Program Update**

Amber Buckingham noted that all of the awardees from the latest round of grant applications have been notified. They have been awarded and contracts are currently routing amongst all of those grantees. In addition, the policies and procedures handbook and potentially some rules are being revamped. The grant committee will be meeting after the holidays to revamp the application process.

**Grant Modification Request for 20-IEC-016 – Iowa State University – Improve Battery Energy Efficiency via Structural Design and 3D Printing for Electric Vehicles – Attachment B**

Amber Buckingham explained the original Principal Investigator (PI) of the project left the university in 2022, as did one of the student researchers. The new PI has had to spend considerable time hiring and retraining a new student researcher, which has delayed progress on the project. The team will use the time extension to continue to collect results and finish the remaining tasks. This is the second no-cost extension for this project. Ms. Buckingham noted the official request did come in after the technical end date of the project but we feel due to the extenuating circumstances that this is a valid request. Our recommendation would be to approve the no cost extension.

Chairperson Anderson asked if there were questions. Dan Nickey asked if the deliverables were the same. Amber Buckingham replied that yes, the

deliverables are the same and they haven't asked for any additional funds. This will be an approximate nine-month extension to July of 2024.

Motion by Lanny Zieman  
Motion I move to approve the no cost extension request for 20-IEC-016.  
Second Dan Nickey  
Roll Call Yes: 10 Abstain: 0  
Motion approved.

**Grant Modification Request for 20-IEC-014 – Iowa State University – Storing Excess Solar/Wind Electricity as Biorenewable Fuels by Electrocatalytic Biomass Conversion – Attachment C**

Amber Buckingham shared the original Co-PI left the university in 2022 which delayed work on this portion of the project. The PI has requested a second no cost extension for this project. Because the project started during the pandemic, post docs were hired in lieu of the originally planned graduate students, which resulted in lower tuition and higher fringe benefit costs. They request moving \$19,500 from domestic travel and student tuition to payroll benefits and supplies and materials to rebalance the budget. The request came in after the official deadline but due to the circumstances, we feel it is a valid request. Staff considers this substantive and requires board approval. Our recommendation would be to approve the no cost extension and budget modification.

Chairperson Anderson asked if there were questions. No questions were asked.

Motion by Anne Kimber  
Motion I move to approve the no cost extension and budget modification request to 20-IEC-014.  
Second Craig Just  
Roll Call Yes: 10 Abstain: 0  
Motion approved.

**Grant Modification Request for 20-IEC-010 – Iowa State University – Development of Low Cost, Safe and High-Performance Sodium Batteries for Wind Energy Storage – Attachment D**

Amber Buckingham reported due to increasing costs, the supplies and materials budget line item for this project has been overspent and ISU is seeking to move funds to rectify that problem. They had to hire more hourly part-time undergrad students to help complete the research. Recruitment and retainment of PhD students continues to be an issue at the university level. The stipend and tuition categories are currently underspent, ISU proposes to move \$32,000 from those line items to the supplies and materials line item to rebalance their spending. No additional funds are being requested. Because this modification is over \$10,000 it does require board approval and our staff recommendation would be to approve the budget modification request.

Chairperson Anderson asked if there were questions. No questions were asked.

Motion by Dan Nickey  
Motion I move to approve the budget modification request to 20-IEC-010.  
Second Lanny Zieman

Roll Call                      Yes: 11   Abstain: 0  
Motion approved.

**Grant Modification Request for 20-IEC-004 – Iowa State University – Toolkit for Identification, Characterization and Energy Evaluation of Low-Efficiency Rural Housing – Attachment E**

Amber Buckingham explained the project team would like to re-budget \$12,371.00 from domestic travel and student and student tuition to salary, fringe benefits and indirect costs. The re-budget would allow the project team to increase student efforts to assist with finishing the required project tasks and develop and test the toolkit that they are creating. The budget modification request is over \$10,000, so it does require board approval and our staff recommendation would be to approve the budget modification request. Ms. Buckingham noted that the reason that the domestic travel is underspent is because this project was started during the pandemic and so they weren't able to travel as freely as originally planned in 2019.

Chairperson Anderson asked if there were questions. No questions were asked.

Motion by                      Craig Just  
Motion                          I move to approve the budget modification request to 20-IEC-004.  
  
Second                         Dan Nickey  
Roll Call                       Yes: 10   Abstain: 1 (Kimber)  
Motion approved.

**Grant Modification Request for 21-IEC-010 – Iowa State University – Advanced 3D Optical Sensing and Peening Technologies for Crack Mitigation in Natural Gas Pipelines – Attachment F**

Amber Buckingham shared in order to complete the project as scheduled, the PI recruited an additional graduate student to work on the project. Additional material purchases and travel funds will not be utilized, so ISU would like to move \$23,101.00 from those line items to salary and payroll benefits. This budget modification is over \$10,000 and therefore requires board approval and our staff recommendation would be to approve the budget modification request.

Chairperson Anderson asked if there were questions. No questions were asked.

Motion by                      Lanny Zieman  
Motion                          I move to approve the budget modification request to 21-IEC-010.  
  
Second                         Dan Nickey  
Roll Call                       Yes: 11   Abstain: 0  
Motion approved.

**Energy Infrastructure Revolving Loan Program (EIRLP) – EIRLP Update –**

Stephanie Weisenbach provided a general update on the loan program application cycles. The loan program did receive one application. The loan committee met and reviewed the details of that application and then went back to the applicant with some further negotiations and requests for clarification that the applicant is still working on. We're working with that applicant to see if those requested changes can be met, so more to come on that and we are expecting at least one application in the next cycle. People have a tendency to check in

with us months in advance, which is great, but we don't always know which quarter it's going to land in or if they're going to end up applying. But we have heard about two projects that plan to apply it in the next cycle.

**Energy Infrastructure Revolving Loan Program Policies and Procedures Update – Attachment G**

Stephanie Weisenbach explained the policies and procedures document is provided on our program web page and it provides the framework and requirements of the program, which includes, some key pieces from Iowa code from the administrative rules that have been adopted and some other policies and procedures that can be updated and revised by the board annually. We also have a rule that we review this annually to provide any necessary updates to just make sure we're staying in alignment with the board's vision for the program. We have a few proposed changes to the document that make sure that the outward facing document is consistent with how the program is actually operating. The first change relates to the collateral for the project and what we found through the program is that sometimes we want more than one form of collateral in order to provide the optimum security for the loan and currently the policies and procedures lists what we accept and it doesn't make it really clear that we could be needing more than one form. We are also clarifying that any solar project, not just private sector projects, which was the previous language, any solar project should incorporate additional technologies and innovative approaches. This was discussed at a previous full board meeting and now is being solidified in this document to ensure that we're getting the kinds of applications that the board wants to see. The 3rd update is providing an additional deadline option for what we call a start-up report that we require when the project is finished. And that's when we get a chance to review all the invoices and learn about lessons learned from the project and make sure they have the appropriate permits. The current option for the deadline was 60 days of the project being placed in service. We're making it an additional document or the latest date for all project invoices. Wanting to make sure that we're getting the documentation we want and not creating a requirement that doesn't make sense for these types of situations. The recommendation from staff and the loan committee would be to approve these changes to the EIRLP policies and Procedures Handbook.

Ms. Weisenbach asked if there were questions; no questions were asked.

Motion by	Craig Just
Motion	I move to approve changes to the EIRLP policies and procedures
Second	Anne Kimber
Roll Call	Yes: 11 Abstain: 0

Motion approved.

**Algae Biomass Organization – Attachment H**

Jon Kallen with Algae Biomass Organization, made a presentation on Algae Biomass Organization

**Sunflower Child Development and Discovery Center – Attachment I**

Stephanie Fromm with Winneshiek County Development and Tourism, made a presentation on Sunflower Child Development and Discovery Center

**Renewable Energy Mobile Batteries Powering Decentralized Wastewater Treatment and Emergency Response – Attachment J**

Nathan Seberg with BES Water Solutions, made a presentation on Renewable Energy Mobile Batteries Powering Decentralized Wastewater Treatment and Emergency Response

**Other Business**

Stuart Anderson turned it over to Brian Selinger to give Energy Office updates.

**Energy Center Office Updates**

Brian Selinger shared that he has accepted an opportunity in the private sector with ITC Midwest. He is proud of how far we've come as a center and appreciates the collective team, IEDA, IFA, and the board. After almost nine years with IEDA and with Director Durham at the helm, it's a lot for me to digest, but I'm excited for the new opportunity and hope to cross paths with you guys and I'm extremely bullish on the future of the Iowa Energy Center.

Shelly Peterson is going to lead in the interim basis. IDEA has posted the position and it closes tomorrow.

**Public Comment Period**                      No public comments.

Chairperson Anderson adjourned the meeting.

**Adjournment**                                      2:31 p.m.

Respectfully Submitted,  
Michelle Cook, IEC Board Administrator

Attachment A

INFO

**REPORT  
IOWA ENERGY CENTER BOARD  
NOVEMBER 2023**

From: Administration Division

Subject: IEC Financial Report(s)

Attached please find the financial information for the Iowa Energy Center programs.

---

**Proposed Motion:**      **No Action Required**

---

Submitted By: Terry Roberson

Attachments: Financial Reports for Iowa Energy Center

<b>IEDA</b>			
<b>Financial Report</b>			
<b>Iowa Energy Center</b>			
<b>Fiscal Year 2024</b>			
<b>October 31, 2023</b>			
	<b>IEC Main</b>	<b>Alt Energy</b>	<b>IEC Loan</b>
	<b>Fund</b>	<b>Infr Loan</b>	<b>Fund (prev )</b>
<u>Revenue</u>			
Cash Balance Forward	16,482,329	15,538,704	506,669
Principal Repayments YTD	0	7,173	133,885
Interest Revenue	187,610	170,223	5,635
Other Revenue YTD	0	1,523	0
Deappropriations	0	0	0
Transfers	0	0	0
<b>Total Revenue YTD</b>	<b>16,669,939</b>	<b>15,717,623</b>	<b>646,189</b>
<u>Expenses</u>			
Administration YTD	(51,618)	(9,774)	0
Project Payouts YTD	(96,737)	(907,000)	0
Leg Auth Transfers	0	0	0
(18 Acts Ch 1172 Sec 91)	0	0	0
<b>Total Expense YTD</b>	<b>(148,355)</b>	<b>(916,774)</b>	<b>0</b>
<u>Obligations</u>			
Obligations C/F	4,593,084	3,593,000	348,810
Current Year Obligations	1,583,407	0	0
Current Year Rescissions	0	0	0
Current Year Payouts	(96,737)	(907,000)	0
Balance of Current Year Admin	128,382	34,226	0
<b>Net Obligations YTD</b>	<b>6,208,136</b>	<b>2,720,226</b>	<b>348,810</b>
<b>Balance Available</b>	<b>10,313,448</b>	<b>12,080,623</b>	<b>297,379</b>





**REPORT  
IOWA ENERGY CENTER BOARD  
NOVEMBER 2023**

From: Iowa Energy Office

Subject: 20-IEC-016 Grant Modification

**Background:** Iowa State University (ISU) has requested no cost extension for award 20-IEC-016 *Improve Battery Energy Efficiency via Structural Design and 3D Printing for Electric Vehicles*.

The original Principal Investigator (PI) of the project left the university in 2022, as did one of the student researchers. The new PI has had to spend considerable time hiring and retraining a new student researcher, which has delayed progress on the project. The team will use the time extension to continue to collect results and finish the remaining tasks. This is the second no-cost extension for this project.

Administrative Rule 261 IAC 404.7(7)(a) provides that any substantive change to a funded IEC project, including time extensions, budget revisions, and alterations to proposed activities, will be considered an agreement amendment. As this is the second no cost extension, staff consider this request substantive and requires Board approval.

**Staff Recommendation:** Approve the no cost extension request for 20-IEC-016.

---

**Proposed Motion:** Approve the no cost extension request for 20-IEC-016

---

Submitted By: Amber Buckingham

Attachments: 20-IEC-016 No Cost Extension Request.

IOWA STATE UNIVERSITY  
OF SCIENCE AND TECHNOLOGY

Office of Sponsored  
Programs Administration  
1138 Pearson Hall  
505 Morrill Road  
Ames, Iowa 50011-2103  
Phone: 515 294-5225  
Fax: 515 294-8000

October 31, 2023

Amber Buckingham  
[Amber.Buckingham@IowaEDA.com](mailto:Amber.Buckingham@IowaEDA.com)

**SUBJECT:** Request for No-Cost Extension  
**Award Number:** 20IEC016  
**ISU Account:** AWD-023370 **ISU ID:** 148594  
**ISU PI:** Shan Hu

Dear Amber Buckingham,

The above referenced award was made to Iowa State University and has a current end date of 9/25/2023. I am in receipt of a letter from the Principal Investigator, Dr. Shan Hu requesting a no-cost extension to complete the work being undertaken on this project.

The original PI has left the university and took away student researcher working on this project as well as some equipment needed to complete the work. Dr. Hu has spent extra time to re-build the equipment needed and hire/train newly recruited student researcher, which delayed the progress.

Using the remaining funds of \$6500, we will continue to collect results and finish the remaining tasks (i.e. testing battery cells to prove the proposed design and manufacturing technology can enhance the energy efficiency of batteries).

Iowa State University has carefully reviewed the request and concurs therein. **We request that the termination date be changed from 9/25/2023 to 7/31/2024.** All other terms and conditions remain unchanged. If I can provide you with additional information or be of further assistance, please do not hesitate to contact our office.

Sincerely,



---

Shan Hu PhD  
Associate Professor, Mechanical Engineering



Digitally signed by Lora Bierbaum  
Location: Office of Sponsored  
Programs Administration, Iowa  
State University  
Date: 2023.10.31 13:15:58 -0500

---

Lora Bierbaum  
Award Administrator

cc: Shan Hu  
RRC

**ACTION**

**REPORT  
IOWA ENERGY CENTER BOARD  
NOVEMBER 2023**

From: Iowa Energy Office

Subject: 20-IEC-014 Grant Modification

**Background:** Iowa State University (ISU) has requested no cost extension and budget modification for award 20-IEC-014 *Storing Excess Solar/Wind Electricity as Biorenewable Fuels by Electrocatalytic Biomass Conversion*.

The original Co-Principal Investigator (Co-PI) of the project left the university in 2022, which delayed work on his portion of the project, so the PI has requested a second no-cost extension for this project. The project also started during the pandemic and post docs were hired in lieu of the originally planned graduate students, which resulted in lower tuition and higher fringe benefit costs. ISU requests that \$19,5000 are moved from the domestic travel and student tuition line items to payroll benefits and supplies and materials.

Administrative Rule 261 IAC 404.7(7)(a) provides that any substantive change to a funded IEC project, including time extensions, budget revisions, and alterations to proposed activities, will be considered an agreement amendment. As this is the second no cost extension, and the budget modification is over \$10,000, staff consider this request substantive and requires Board approval.

**Staff Recommendation:** Approve the no cost extension and budget modification request for 20-IEC-014.

---

**Proposed Motion:** Approve the no cost extension and budget modification request for 20-IEC-014

---

Submitted By: Amber Buckingham

Attachments: 20-IEC-014 No Cost Extension and Budget Modification Request.

**IOWA STATE UNIVERSITY**  
OF SCIENCE AND TECHNOLOGY

Office of Sponsored  
Programs Administration  
1138 Pearson Hall  
505 Morrill Road  
Ames, Iowa 50011-2103  
Phone: 515 294-5225  
Fax: 515 294-8000

October 27, 2023

Amber Buckingham  
[Amber.Buckingham@IowaEDA.com](mailto:Amber.Buckingham@IowaEDA.com)

**SUBJECT:** Request for No-Cost Extension  
**Award Number:** 20IEC014  
**ISU Account:** AWD-023372 **ISU ID:** 148650  
**ISU PI:** Shan Hu

Dear Ms. Buckingham,

The above referenced award was made to Iowa State University and has a current end date of 9/25/2023. I am in receipt of a letter from the Principal Investigator, Dr. Shan Hu requesting a no-cost extension and rebudget of funds to complete the work being undertaken on this project.

Multiple factors contributed to the need for a no-cost extension and rebudget of funds. A co-investigator on the project, Dr. Hantang Qin, left ISU during the project period, delaying his portion of the work. The project started during the COVID-19 pandemic and recruitment of graduate students was difficult, so postdocs who were already on campus were hired. This required a higher fringe benefits rate than graduate students, and substantially lower tuition. Due to global supply chain challenges, the prices for materials and supplies went up substantially during the project period. The need for travel during the pandemic was eliminated as meetings were moved to online format. The requested budget revisions are as follows:

<b>Increase:</b>		<b>Decrease:</b>	
Payroll Benefits	\$16,500	Domestic Travel	\$ 7,500
<u>Supplies/Materials</u>	<u>\$ 3,000</u>	<u>Student Tuition</u>	<u>\$12,000</u>
<b>Total</b>	<b>\$19,500</b>	<b>Total</b>	<b>\$19,500</b>

Iowa State University has carefully reviewed the request and concurs therein. **We request that the termination date be changed from 9/25/2023 to 7/31/2024.** All other terms and conditions remain unchanged. If I can provide you with additional information or be of further assistance, please do not hesitate to contact our office.

Sincerely,



Shan Hu, PhD  
Associate Professor, Mechanical Engineering



Pamela Helfer  
Iowa State University, Office of  
Sponsored Programs  
Administration  
2023.10.27 15:41:47 -05'00'

Pamela Helfer  
Senior Award Administrator, OSPA

**REPORT  
IOWA ENERGY CENTER BOARD  
NOVEMBER 2023**

From: Iowa Energy Office

Subject: 20-IEC-010 Grant Modification

**Background:** Iowa State University (ISU) has requested a budget modification for award 20-IEC-010 *Development of Low Cost, Safe and High-Performance Sodium Batteries for Wind Energy Storage*.

Due to increasing costs, the supplies and materials budget for this project has been overspent, and ISU is seeking to move funds to rectify the problem. As the PI also had to hire more hourly parttime undergrad students to help complete the research (since the recruitment and retainment of PhD students continues to be an issue at the university level) the stipend and tuition categories are currently underspent. ISU would like to move \$32,000 from those line items to the supplies and materials line time to rebalance their spending.

Administrative Rule 261 *IAC* 404.7(7)(a) provides that any substantive change to a funded IEC project, including time extensions, budget revisions, and alterations to proposed activities, will be considered an agreement amendment. As the budget modification is over \$10,000, staff consider this request substantive and requires Board approval.

**Staff Recommendation:** Approve the budget modification request for 20-IEC-010.

---

**Proposed Motion:** Approve the budget modification request for 20-IEC-010

---

Submitted By: Amber Buckingham

Attachments: 20-IEC-010 Budget Modification Request.

**IOWA STATE UNIVERSITY**  
OF SCIENCE AND TECHNOLOGY

Office of Sponsored  
Programs Administration  
1138 Pearson Hall  
505 Morrill Road  
Ames, Iowa 50011-2103  
Phone: 515 294-5225  
Fax: 515 294-8000

October 28, 2023

Amber Buckingham  
Amber.Buckingham@IowaEDA.com

**SUBJECT:**

**Award Title:** Development of high energy, density safe, low cost, all solid state Sodium batteries for wind energy storage in Iowa.

**Sponsor Reference Number:** 20IEC010

**Revised Budget Request**

**ISU Account:** AWD-022375

**ISU ID:** GS 145693

**ISU PI:** Steve Martin

Dear Ms. Buckingham:

The above referenced grant was made to Iowa State University in the amount of \$480656 under the direction of Dr. Steve Martin who has requested that budget categories be adjusted as prescribed below and per the justification.

**Justification:** The cost of everything has been increasing dramatically recently with inflation averaging more than 6%. This is even more the case with materials and supplies. One chemical our project depends upon heavily is Na<sub>2</sub>S. It now costs more than \$2,500 per pound. As a result of skyrocketing costs of materials and supplies we have overspent this category. Combined with this problem has been record low employment which has made it very difficult to recruit, hire and retain PhD students. For this reason, I have been unable to hire the full complement of research students for this project. I have been able to hire more hourly parttime undergraduate students to help complete the research. The result of all of these is that our stipend and tuition categories are underspent and our hourly undergraduate salary and materials and supplies categories are overspent. I would like to rebudget to get our supplies category back to a positive balance using unspent tuition.

We at Iowa State University have reviewed Dr. Martin's request and concur therein. Therefore, we request approval for the attached revised budget. If I can provide you with additional information or be of further assistance, please do not hesitate to contact me.

Sincerely,



10/28/2023

Jeff Kleth

Senior Award Administrator

Office of Sponsored Programs Administration

cc: Steve Martin  
Tom Coy

**Budget categories to be adjusted:**

INCREASE			DECREASE		
Salary/Hourly (0108)	\$	11,400	Salary/Hourly (0108)	\$	
Payroll Benefits (0130)	\$	2,450	Payroll Benefits (0130)	\$	
Equipment (0710)	\$		Equipment (0710)	\$	
Domestic Travel (0215)	\$	1,257	Domestic Travel (0215)	\$	
Foreign Travel (0216)	\$		Foreign Travel (0216)	\$	
Student Tuition (0610)	\$		Student Tuition (0610)	\$	32,000
Supply/Materials (0410)	\$	11,893	Supply/Materials (0410)	\$	
<i>Subcontracts</i>			<i>Subcontracts</i>		
Burdenable (0396)	\$		Burdenable (0396)	\$	
Nonburdenable (0376)	\$		Nonburdenable (0376)	\$	
<i>Other Direct Costs</i>			<i>Other Direct Costs</i>		
Telecommunications (0340)	\$		Telecommunications (0340)	\$	
Computing (0353)	\$		Computing (0353)	\$	
Printing/Copying (0373)	\$		Printing/Copying (0373)	\$	
Honoraria/Services (0302)	\$		Honoraria/Services (0302)	\$	
Postage (0379)	\$		Postage (0379)	\$	
Other (0630)	\$	5,000	Other (0630)	\$	
TOTAL DIRECT COSTS		\$ 32,000	TOTAL DIRECT COSTS		\$ 32,000
Indirect Costs (0642)	Rate: 20%	\$	Indirect Costs (0642)	Rate: 20%	\$
TOTAL ALL COSTS		\$ 32,000	TOTAL ALL COSTS		\$ 32,000

*The total costs increased must equal the total costs decreased.*



**ACTION**

**REPORT  
IOWA ENERGY CENTER BOARD  
NOVEMBER 2023**

From: Iowa Energy Office

Subject: 20-IEC-004 Grant Modification

**Background:** Iowa State University (ISU) has requested a budget modification for award 20-IEC-004 *Toolkit for Identification, Characterization and Energy Evaluation of Low-Efficiency Rural Housing*.

The project team would like to rebudget \$12,371 from domestic travel and student tuition to salary, fringe benefits and indirect costs. This rebudget would allow the project team to increase student efforts to assist with finishing the required project tasks and develop and test the toolkit.

Administrative Rule 261 IAC 404.7(7)(a) provides that any substantive change to a funded IEC project, including time extensions, budget revisions, and alterations to proposed activities, will be considered an agreement amendment. As the budget modification is over \$10,000, staff consider this request substantive and requires Board approval.

**Staff Recommendation:** Approve the budget modification request for 20-IEC-004.

---

**Proposed Motion:** Approve the budget modification request for 20-IEC-004

---

Submitted By: Amber Buckingham

Attachments: 20-IEC-004 Budget Modification Request.

**IOWA STATE UNIVERSITY**  
OF SCIENCE AND TECHNOLOGY

Office of Sponsored  
Programs Administration  
1138 Pearson Hall  
505 Morrill Road  
Ames, Iowa 50011-2103  
Phone: 515 294-5225  
Fax: 515 294-8000

September 27, 2023

Amber Buckingham  
Program Manager, Energy Team  
Iowa Economic Development Authority  
1963 Bell Avenue, Suite 200  
Des Moines, IA 50315

**SUBJECT: Agreement 20-IEC-004, Rebudget Request**  
ISU AWD-022210; ISU Proposal 146233  
ISU PI: Anne Kimber

Dear Amber:

The above referenced agreement was made to Iowa State University in the amount of \$287,354 under the direction of Dr. Anne Kimber. In the review of account records, Iowa State University has learned that a rebudget of funds is required to properly document the accounting for this project, hence, ISU is requesting the following revisions to this budget:

**Increase:**

Salary, \$10,276  
Fringe Benefits, \$1,099  
Indirect Costs, \$1,356  
Total \$12,731

**Decrease:**

Domestic Travel, \$4,594  
Student Tuition, \$8,137  

---

Total \$12,731

The rebudget is requested because less travel was utilized than originally planned, and too much tuition was originally budgeted at time of proposal. We would like to increase our student effort to assist with finishing the required project tasks, particularly to develop and test the toolkit software.

We at Iowa State University have reviewed Dr. Kimber's request and concur therein. Therefore, we request approval for the revised budget. If I can provide you with additional information or be of further assistance, please do not hesitate to contact me.

Sincerely,



Marva Ruther  
Senior Award Administrator  
Office of Sponsored Programs Administration

Digitally signed by  
Marva Ruther, Senior  
Award Administrator  
Date: 2023.09.27  
11:23:40 -05'00'

c: Anne Kimber  
Samantha Dubert

**ACTION**

**REPORT  
IOWA ENERGY CENTER BOARD  
NOVEMBER 2023**

From: Iowa Energy Office

Subject: 21-IEC-010 Grant Modification

**Background:** Iowa State University (ISU) has requested a budget modification for award 21-IEC-010 *Advanced 3D Optical Sensing and Peening Technologies for Crack Mitigation in Natural Gas Pipelines*.

In order to complete the project as scheduled, the PI recruited an additional graduate student to work on the project. Additional material purchases and travel funds will not be utilized, and ISU would like to move \$23,101 from these line items to salary and payroll benefits.

Administrative Rule 261 IAC 404.7(7)(a) provides that any substantive change to a funded IEC project, including time extensions, budget revisions, and alterations to proposed activities, will be considered an agreement amendment. As the budget modification is over \$10,000, staff consider this request substantive and requires Board approval.

**Staff Recommendation:** Approve the budget modification request for 21-IEC-010.

---

**Proposed Motion:** Approve the budget modification request for 21-IEC-010

---

Submitted By: Amber Buckingham

Attachments: 21-IEC-010 Budget Modification Request.

IOWA STATE UNIVERSITY  
OF SCIENCE AND TECHNOLOGY

Office of Sponsored  
Programs Administration  
1138 Pearson Hall  
505 Morrill Road  
Ames, Iowa 50011-2103  
Phone: 515 294-5225  
Fax: 515 294-8000

October 27, 2023

Amber Buckingham  
Amber.Buckingham@IowaEDA.com

**SUBJECT:**

**Award Title:** Natural gas pipeline rehabilitation via advanced 3D optical sensing  
And Peening Technologies.

**Sponsor Reference Number:** 21IEC010

**Revised Budget Request**

**ISU Account:** AWD-024875

**ISU ID:** GS 151511

**ISU PI:** Beiwen Li

Dear Ms. Buckingham:

The above referenced grant was made to Iowa State University in the amount of \$255,472.00 under the direction of Dr. Beiwen Li who has requested that budget categories be adjusted as prescribed below and per the justification.

**Justification:** We recruited an additional graduate student to work on this award. Material purchases and conference travels are no longer needed for the remaining work of this grant.

We at Iowa State University have reviewed Dr. Li's request and concur therein. Therefore, we request approval for the attached revised budget. If I can provide you with additional information or be of further assistance, please do not hesitate to contact me.

Sincerely,

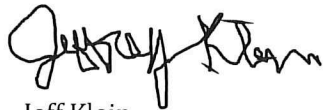

10/27/2023

Jeff Klein  
Senior Award Administrator  
Office of Sponsored Programs Administration

cc: Beiwen Li  
Tiffany Wood

**Budget categories to be adjusted:**

INCREASE			DECREASE		
Salary/Hourly (0108)	\$	14,101	Salary/Hourly (0108)	\$	
Payroll Benefits (0130)	\$	9,000	Payroll Benefits (0130)	\$	
Equipment (0710)	\$		Equipment (0710)	\$	
Domestic Travel (0215)	\$		Domestic Travel (0215)	\$	3,464
Foreign Travel (0216)	\$		Foreign Travel (0216)	\$	
Student Tuition (0610)	\$		Student Tuition (0610)	\$	
Supply/Materials (0410)	\$		Supply/Materials (0410)	\$	19,637
<i>Subcontracts</i>			<i>Subcontracts</i>		
Burdenable (0396)	\$		Burdenable (0396)	\$	
Nonburdenable (0376)	\$		Nonburdenable (0376)	\$	
<i>Other Direct Costs</i>			<i>Other Direct Costs</i>		
Telecommunications (0340)	\$		Telecommunications (0340)	\$	
Computing (0353)	\$		Computing (0353)	\$	
Printing/Copying (0373)	\$		Printing/Copying (0373)	\$	
Honoraria/Services (0302)	\$		Honoraria/Services (0302)	\$	
Postage (0379)	\$		Postage (0379)	\$	
Other (0630)	\$		Other (0630)	\$	
<b>TOTAL DIRECT COSTS</b>	<b>\$</b>	<b>23,101</b>	<b>TOTAL DIRECT COSTS</b>	<b>\$</b>	<b>23,101</b>
Indirect Costs (0642) Rate: 25%	\$	5,775	Indirect Costs (0642) Rate: 25%	\$	5,775
<b>TOTAL ALL COSTS</b>	<b>\$</b>	<b>28,876</b>	<b>TOTAL ALL COSTS</b>	<b>\$</b>	<b>28,876</b>

*The total costs increased must equal the total costs decreased*

**REPORT  
IOWA ENERGY CENTER BOARD  
November 2023**

From: Iowa Energy Center Staff

Subject: Proposed Changes to Policies and Procedures, Energy Infrastructure Revolving Loan Program (EIRLP)

**Background:**

The policies and procedures for the Energy Infrastructure Revolving Loan Program is a document to provide the requirements and the framework of how the program will be administered. The current version is available on the program webpage.

The administrative rules for the EIRLP require this document to be reviewed and approved by the IEC Board at least once per year and will remain in effect until any changes are adopted by the board. The Loan Committee discussed the currently proposed changes at their recent meeting.

**Proposed Changes:**

- Clarify more than one form of collateral may be required and that IEDA and the board have final discretion to determine acceptable collateral from a particular applicant. This has already been the outcome of some applications reviewed in the program.
- Clarify any solar project must incorporate additional technologies and innovative approaches. Previous language was focused on private-sector projects.
- Provide an additional deadline option for start-up report after project completion to be within sixty days of the project being placed in service/operational *or* the latest date for all project invoices. Previous language was restricted to the first deadline and the start-up report requires all project expense invoices to be submitted, which can create conflicting requirements when delayed expenses and invoices occur.

---

**Proposed Motion:** “Approve changes to the EIRLP policies and procedures”

---

Submitted By: Stephanie Weisenbach, Program Manager

Attachments: None

# ALGAE BIOMASS ORGANIZATION

Attachment H

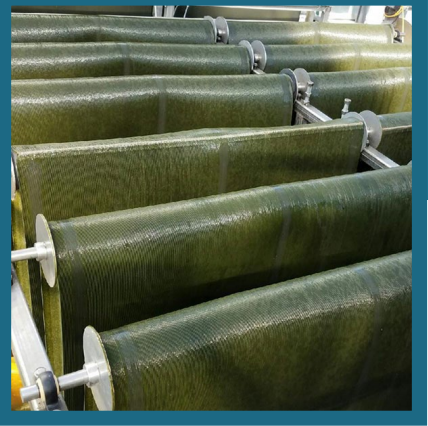
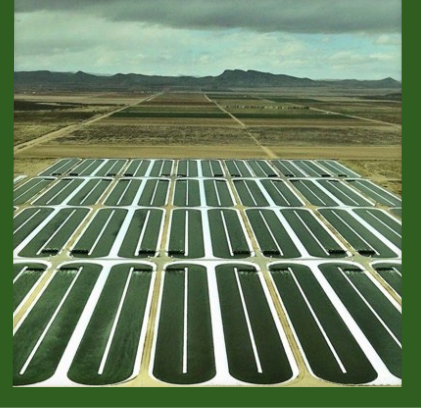

# Who we Are

- Founded in 2008. Now headquartered in downtown Des Moines, Iowa. (moved to Iowa in August 2023 from MN). 3 Staffers (one PT Executive Director, Administrative/Marketing Coordinator, Communications Specialist).
- World's largest algae non-profit trade association. Annual Conference in the fall of each year. (last year in Madison, this year in Phoenix).
- Over 150 members (**and growing fast**) in United States, Canada, Australia and Europe to include commercial companies, academic institutions, national laboratories, non-profits, federal agencies, consulting/affiliated companies.
- Commercial companies involved in feed, food, consumer products (dyes, biobased inputs), regenerative agriculture, wastewater treatment, harmful algae-bloom remediation, SAF.
- Tons of investment activity in commercial companies in 2022 -2023 – (ex. see below)





# Who we Are

- Some of our Members (over 150) –



College of Engineering  
Wastewater and Waste to Energy  
Research Program



BLUE OCEAN  
BARN



- **ABO has many member offerings to support the growth of the algae sector to include –**
  - Advisory Committees for Water Treatment/Environmental Resources, SAF, Regenerative Agriculture, Feed/Food
  - Government Relations - track federal legislation, funding, interface with federal agencies (EPA, DOE, USDA).
  - Newsletters, programming (webcasts), member portal for sharing/dissemination of info.
  - Member Affinity programs
    - Ex. discounted analytical lab testing with our partner **Eurofins Craft**



# WHAT IS ALGAE?

# Algae – the SUPER organism!

- **Not a PLANT, FUNGI, BACTERIA or ANIMAL.**
- Is a Large and Diverse Group of photosynthetic (some mixotrophic – carbon/sun), eukaryotic (one or more cells with nuclei), organisms (protists).
- Over 15,000 species!
- **Microalgae** – cyanobacteria (blue-green, spirulina), chlorella, haematococcus, Scenedesmus.
- **Macroalgae** (seaweed) – red, green, brown. Bromoform in red algae inhibits methogenesis (production of methane in ruminants).

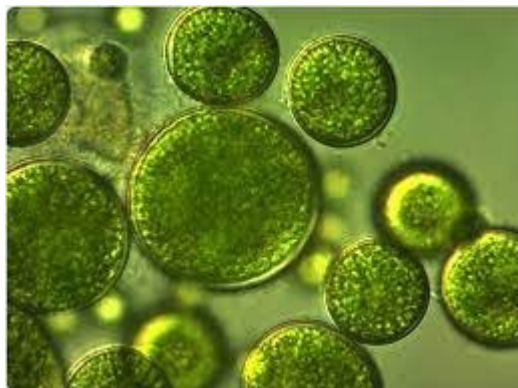

# Algae – the SUPER organism!

- Can grow anywhere – adaptive/resilient.
- Produces many useful compounds – antioxidants, fatty acids (omega-3), enzymes, polymers, peptides, proteins.
- Many commercial uses –
  - Feed
  - Food
  - Cosmetics
  - Fuel
  - Agriculture (fertilizer (high in P), soil amendment (increases organic content))
  - Dyes, inputs (biobased)

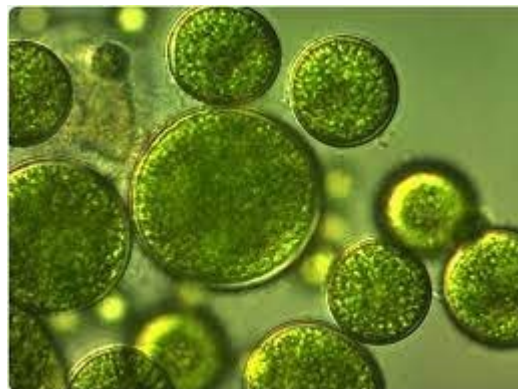

# Algae – Beneficial Attributes

- Algae produces approximately HALF of the world's atmospheric oxygen.
- Algae uses carbon dioxide to grow (update, capture, sequestration). **Each ton of Algae grown captures 2 tons of CO<sub>2</sub>.**

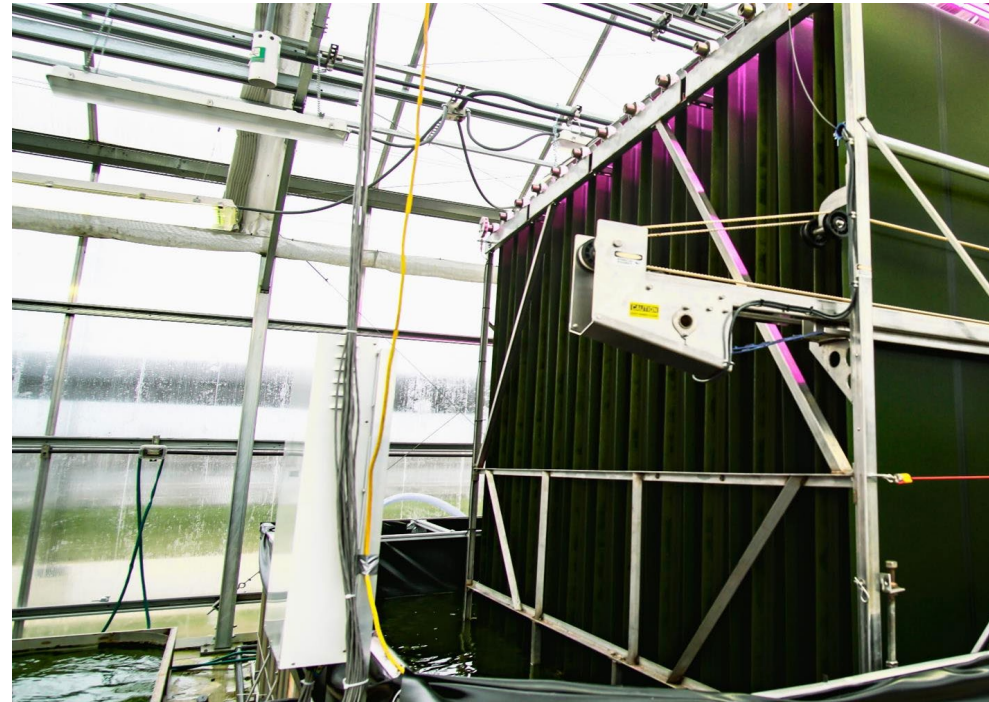



# ALGAE FOR WASTEWATER TREATMENT

- Algae-based WWT is a growing area with installations (over 20 NPDES permitted facilities) throughout the U.S. and pilots worldwide.
- Algae-based treatment offers many advantages –
  - Energy efficiency (lower operating costs).
  - Sustainability (each ton of Algae captures 2 tons of CO<sub>2</sub>)
  - Sellable byproduct (organic fertilizer, inputs for biobased materials, SAF)

# Algae in WWT

Example installations – Algae Wheel, GWT, Clearas

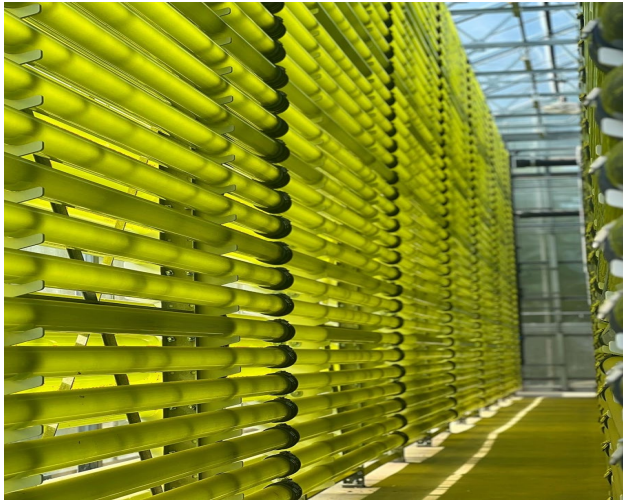
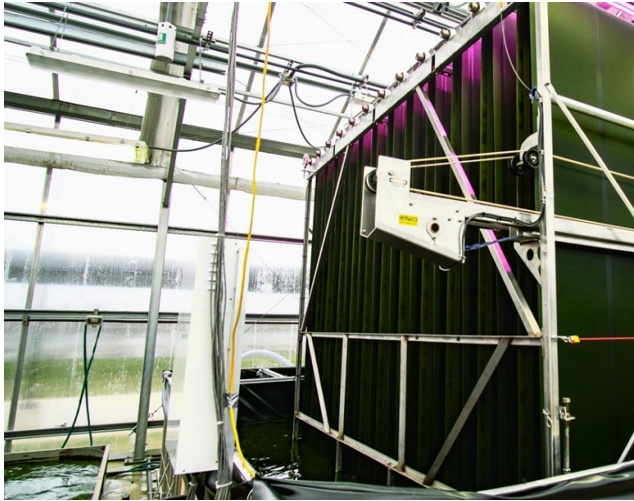





# ALGAE AS SAF

- **Algae will play a key and integral role in SAF and the SAF Grand Challenge (3 billion gallons by 2030/35 billion gallons by 2050)**
- **Key attributes of algae as SAF –**
  - Productivity
    - Current achieved yields from open, large scale, raceway ponds – three times higher than terrestrial crops.
  - Well Suited for Processing in Existing Refining Infrastructure
    - Algae biomass about 1/5<sup>th</sup> fatty acids/derivative oils (i.e. lipids) – suitable for HEFA pathway (ASTM certified).
    - Attractive carbon chain length profile for this HEFA process
    - Under HTL (whole biomass process) – algae biomass ~ 50% carbon content

## Potential Solutions –

- ❖ Lipid content –
  - Ongoing strain development.
- ❖ Scale/Production –
  - Traditional – large, open ponds – lots of land
  - **Production options** – fixed film rotating belts (ex. RAB), Photobioreactors, co-location with WWTP (non-digested sludge as feedstock)

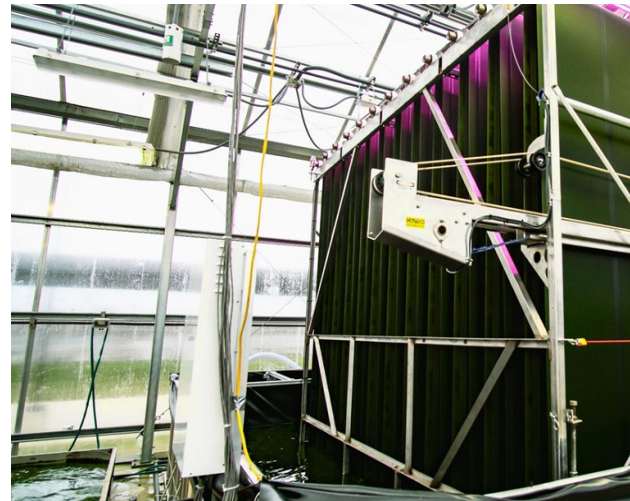

## Potential Solutions –

### ❖ Processing –

- Need a complete supply/production/processing chain (similar to terrestrial crops – farmers, equipment suppliers, processors) (ex. seed corn, John Deere, ADM).
- HTL – need more pilot scale demonstration projects  
Metro Vancouver (2/3 Tons per day)

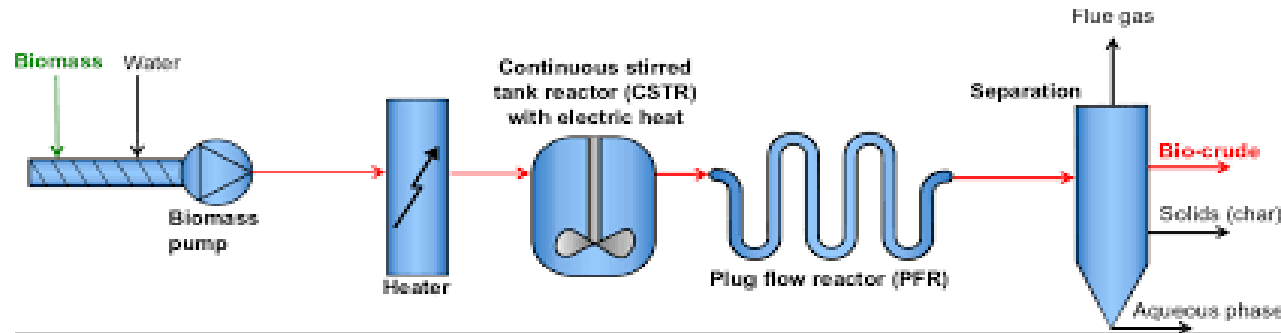



# ALGAE IN AGRICULTURE

# Algae in Agriculture

- Algae has many attributes to assist in regenerative agricultural practices.
  - Use as an animal feed to reduce enteric methane emissions.



- Can increase soil microbial activity, enhance water retention, increase seed germination rates, help move micronutrients from soil to plant.

**CARBONWAVE**



# Algae AND Iowa

- **Iowa as the center of excellence for algae technology in the United States.**
  - **Strengths in agriculture, low-carbon fuels.**
  - **Existing research at ISU, University of Iowa**
  - **Existing Iowa based companies as ABO members (Impac7G, EcoEngineers, UHY, Gross-Wen, GW Nutrition, Cattlemen's Heritage Beef Company, FarmTek/Growspan.**
  - **Recruit companies (ex. Carbonwave).**

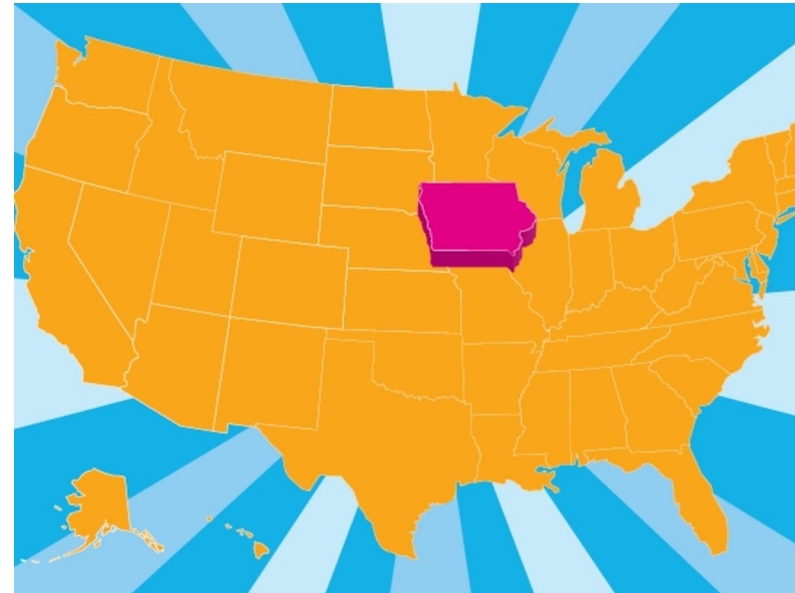

# THANK YOU!

## Contact –

Jon Kallen, M.S., Esq.  
Executive Director (fractional)  
[JKallen@algaebiomass.org](mailto:JKallen@algaebiomass.org)  
Algae Biomass Organization  
666 Walnut Street, 23<sup>rd</sup> Floor  
Des Moines, Iowa 50309

[www.algaebiomass.org](http://www.algaebiomass.org)





*Sunflower's*  
**RESILIENCE**

DECORAH, IOWA

STEPHANIE FROMM  
WINNESHIEK COUNTY DEVELOPMENT & TOURISM



## SUNFLOWER CHILD DEVELOPMENT & DISCOVERY CENTER

# CURRENT FACILITY

- Rehabbed building
- Former church
- Dilapidated
- Limited restrooms
- Typical Issues



# ABOUT

- 501(c)3
- Since 1976
- 37 employees
- 120 children



SUNFLOWER CHILD DEVELOPMENT & DISCOVERY CENTER

# COMMUNITY NEEDS

*It Matters to Children & Families*

- Winneshiek County – Needs
- Wait List
- Decrease in childcare options
- Survey Results
- Goal: “Family Friendly”



# STRATEGIES

- Partnership
- New childcare model
  - Diversify income
  - Increase Pay & Benefits
- **Decrease expenses - Smart Energy**
- Discovery Center



Decorah Water Table

## SUNFLOWER CHILD DEVELOPMENT & DISCOVERY CENTER

# WHY A DISCOVERY CENTER?

- Indoor Playspace
- Tourism
- Different for Families
- Huff Gravity Model

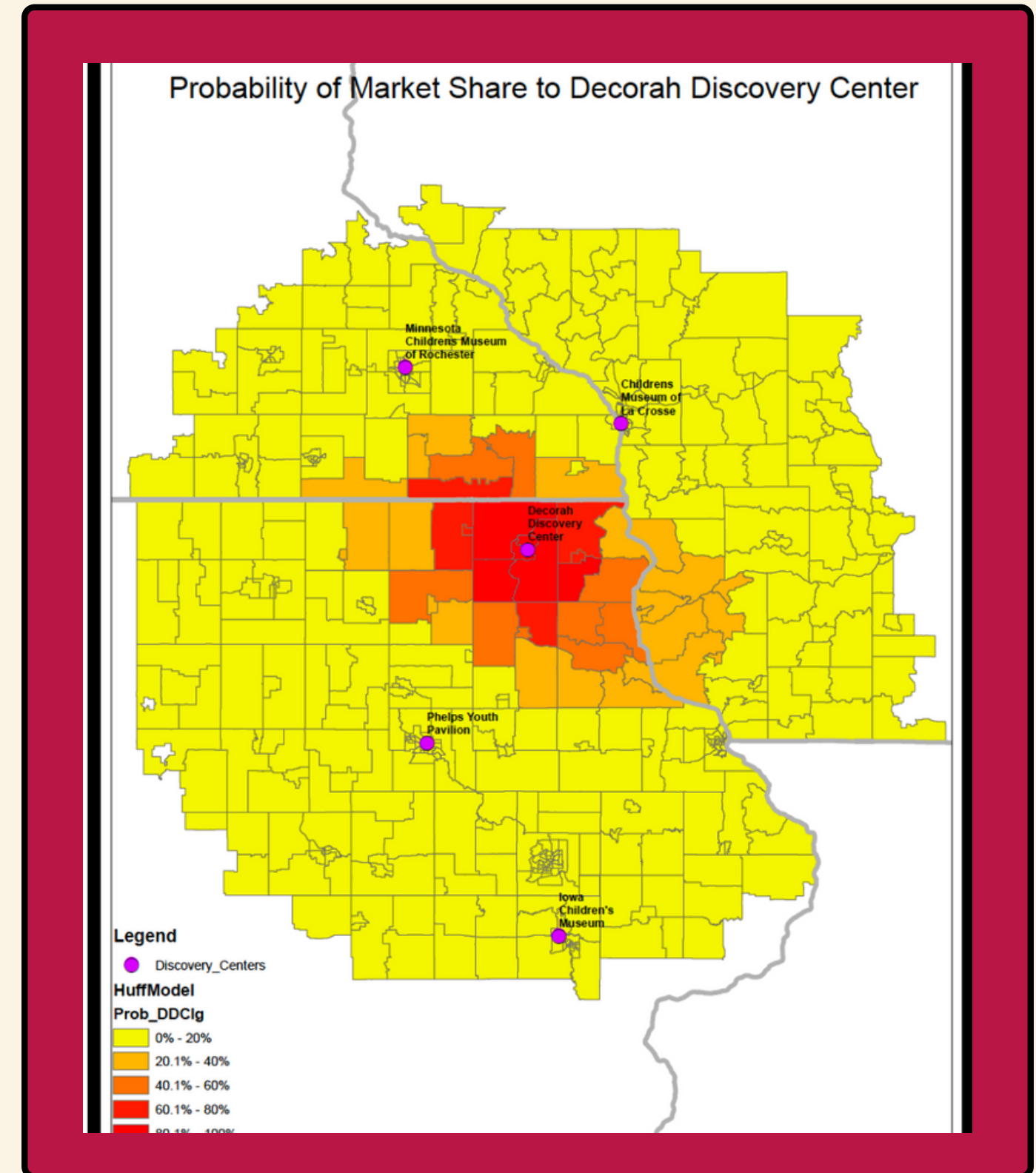

# FUTURE FOCUSED

- SmartFlower
- 60 kW SolarEdge Battery
- Resiliency Package = 80 kW
- 15 kW Generator
- Educational Displays
- Total Solar = 210kW





# Sunflower's Backup Interface

## How it works



210 kW Solar Array.  
Functions normally when grid is on.



Sun charges 60 kW battery storage unit



When the power goes out and grid goes down...

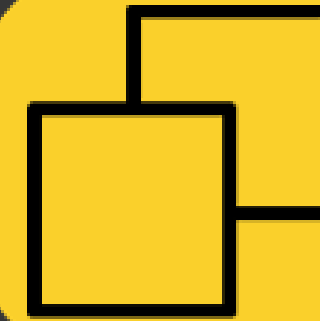

SolarEdge Backup Interface Technology switch from grid to back-up system.



Providing power to data, emergency lighting and heat/ac unit.

*The cool factor with the Backup Interface is that with no utility power, while the sun is out the solar array will still produce as it should - charging the batteries - which will provide power to the emergency panel. At night when the panels are not producing, and if the batteries become depleted, a generator will start automatically. We can also program the batteries to discharge during peak hours to help with demand.*

## SUNFLOWER CHILD DEVELOPMENT & DISCOVERY CENTER

# OTHER ENERGY...

- *Goal: Energy Costs Low!*
- Teach
- Level 2 EV Charger
- Precast Concrete
- EnergyStar Appliances
- LED Lights
- Water Retention





Thank you



# Renewable Energy Mobile Batteries Powering Decentralized Wastewater Treatment and Emergency Response

## Special Thank You:

**IOWA STATE UNIVERSITY**  
**Electric Power Research Center**

Anne Kimber  
Nicholas David

**IOWA**

**College of Engineering**  
Wastewater and Waste to Energy  
Research Program

Craig Just



Walt Jackson – Henry County  
Tim Richmond – Wapello County

**What is rural  
wastewater treatment in Iowa?**

# Rural Iowa Wastewater Treatment

## Aerated Continuous Discharge Lagoon



- Approximately 200 Communities
- Discharges 365 Days Per Year
- High Energy Consumption

## Controlled Discharge Lagoons



- Approximately 500 Communities
- Discharges every 180 Days
- Minimal Energy Consumption

**Can we reach wastewater treatment excellence, and use renewable energy?**



# Alternative Controlled Discharge Treatment



# Microgrid Power Supply

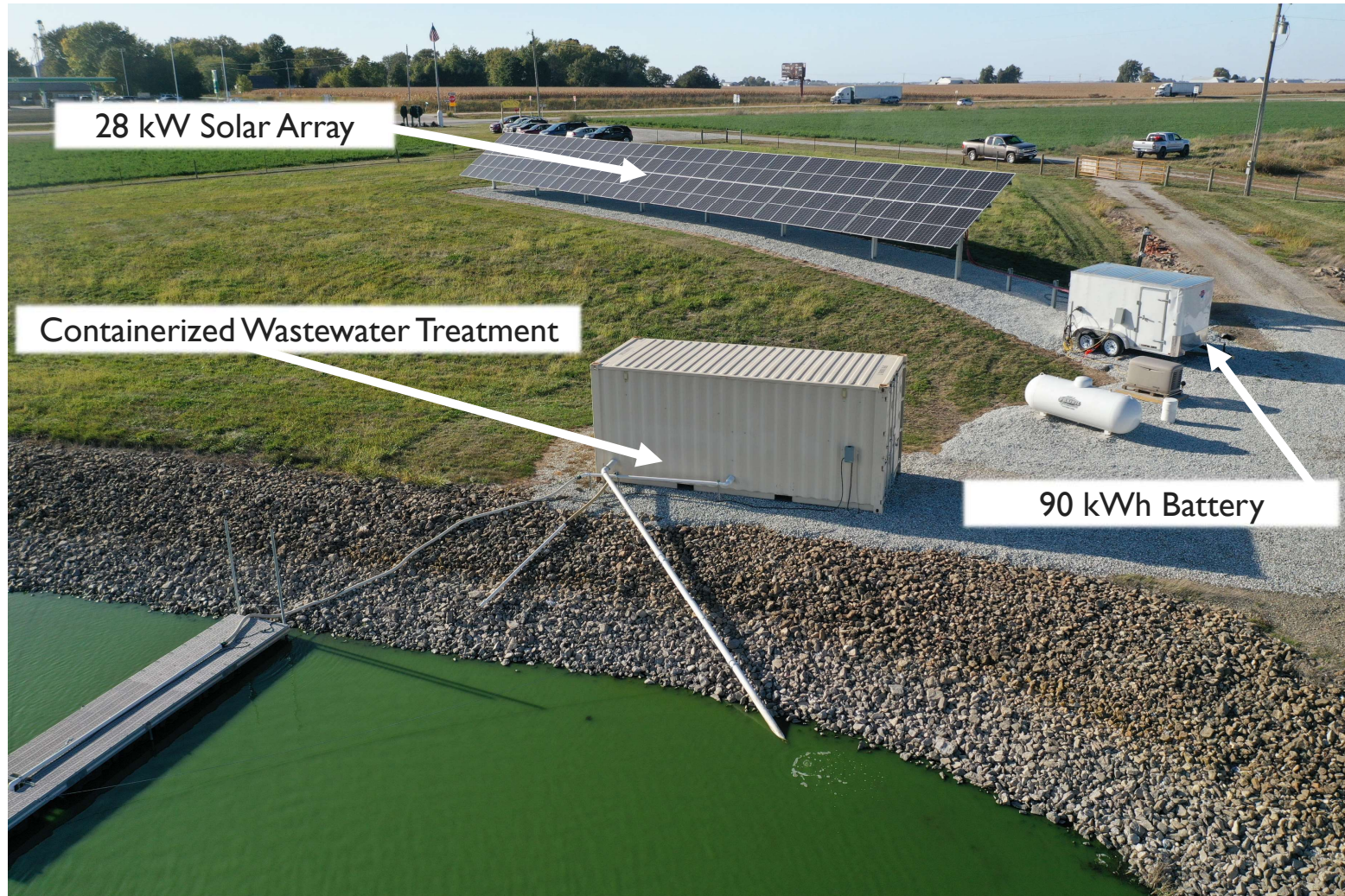

# Emergency Response Integration

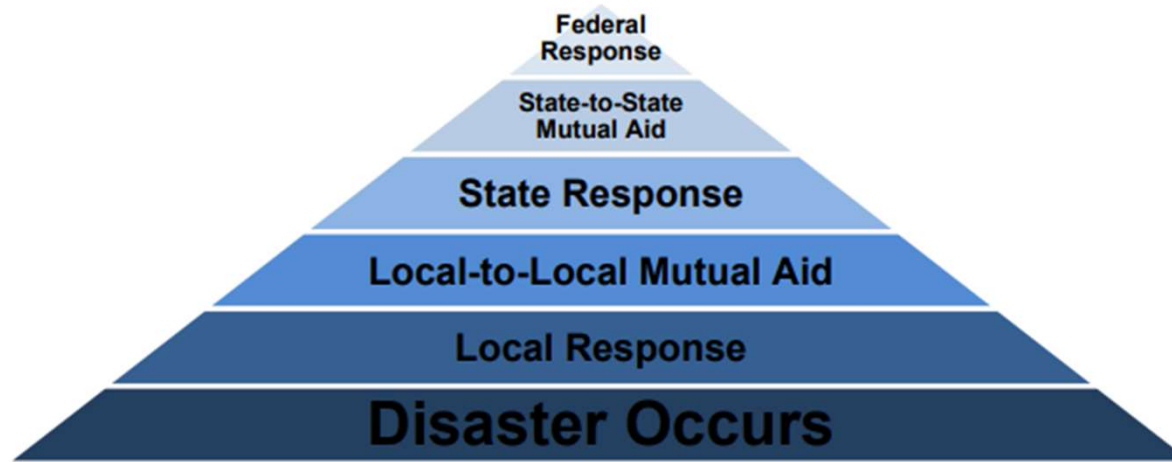

Strategy for the Iowa Department of  
Homeland Security and Emergency  
Management

2021-2023

## IX. STRATEGIC GOALS

### Goal 1: Agile response operations

#### A) Active hybrid EOC teams

Our goal is to transform our organization to ensure we can activate and operate the State Emergency Operations Center (SEOC), with our team and partner agencies responding in person, remotely, or both. This fundamental change in how we operate and respond will be integrated into our plans and procedures, training, emergency exercises, and our physical and technological infrastructure. This will enhance our ability to rapidly and effectively respond, coordinate, collaborate, and execute our mission to serve Iowans.

#### B) Seamless response public/private partnerships

The Public-Private Partnership Program will establish and maintain partnerships to help coordinate mitigation, response, and recovery planning and preparedness efforts.

# Mobile Battery Deployment



Thank You... Questions?

**IOWA STATE UNIVERSITY**  
**Electric Power Research Center**

**IOWA**

**College of Engineering**  
Wastewater and Waste to Energy  
Research Program

